

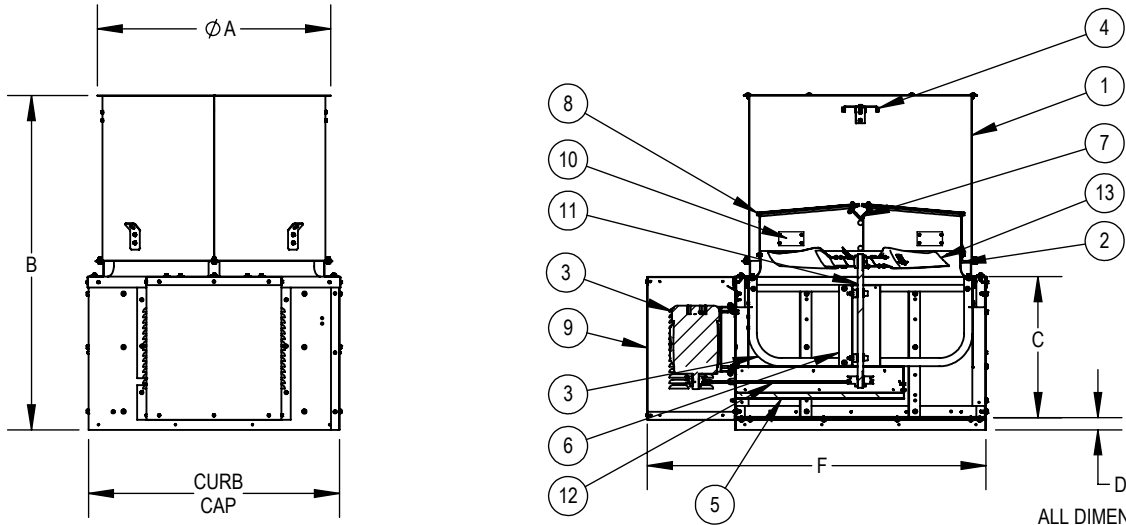

DATE: TAG:
 JOB:
 PROJECT:
 COMPANY:
 SALES PERSON:

PRINT DATE: 7/23/2024

**RAUMO
 MODELS 20 THRU 60**



ALL DIMENSIONS IN INCHES.

DIMENSIONAL DATA

MODEL	A	B	C	D	F	CURB CAP	LESS MOTOR/DRIVE WEIGHT (lbs)
20	28.25	46.88	21.75	2.25	45.68	29.50	226
24	30.50	49.75	21.75	2.25	49.68	33.50	250
30	38.50	56.38	25.75	2.25	55.68	39.50	326
36	42.50	61.00	25.75	2.25	61.68	45.50	395
42	50.75	65.00	25.75	2.25	67.68	51.50	536
48	57.00	69.00	25.75	2.25	73.68	57.50	611
54	61.88	74.88	27.50	2.25	84.16	66.00	800
60	70.88	80.63	29.25	2.25	90.16	72.00	920

LEGEND

- | | | |
|--|-----------------------------|------------------------|
| 1 PROTECTIVE WINDBAND(RIBBED REINFORCED) | 6 DRIVE SUPPORT ASSEMBLY | 10 SUPPORTING BRACKET |
| 2 SPUN INLET VENTURI | 7 DRAINAGE GUTTER | 11 FAN SHAFT & BEARING |
| 3 MOTOR | 8 BUTTERFLY DAMPER ASSEMBLY | 12 BELT & PULLEY |
| 4 DAMPER STOP-RUBBER CUSHIONED | 9 MOTOR WEATHER COVER | 13 PROPELLER (HP & LP) |
| 5 BELT & BEARING ENCLOSURE WITH AIR GUIDE (OPTIONAL) | | |

FEATURES

- Galvanized Steel Construction
- AMCA certified Air and Sound Performance.
- Exhaust or Supply application.
- All propeller statically and dynamically balanced.
- Complies with AMCA Standard 204-96.
- UL 705 Certified

OPTIONS

- Fan Guards
- Safety Disconnect Switches
- Latches
- Finishes
- Roof Curbs

REVISION:

FORM:

REPLACES:

C:\CJ Vault\Penn Barry\Current Products\Axial LWP_RAU_RAUMO_BDS\Submittals\RAUMO\4088